

S-2960/S-2965 Spigot end gate valve DN 80-200

F5 long/extra long

03-05/1039002201/06.2009 **3**
Page 1 of 2

Application and features

- Application: Water and sewage
- S-2960 suitable for replacement of flange valves F5 together with two flange adapters
- S-2965 with flange adapter and/or socket pipes suitable for replacing old valves where cutting the pipe is necessary
- Sturdy stem of stainless steel
- Lockable bayonet connection for telescopic stem extension
- Composite axial and radial sleeve bearing



Technical description

- Pressure class: PN 16, clockwise closing.
- Max. working temperature: 50°C
- Test pressure: Open valve, 24 bar. Closed valve, 17,6 bar
- Bonnet connection: Socket head bolts, recessed and covered with wax
- Stem: Non-rising with tapered stem end. Pitch 1:20 (see table) According to DIN 87304
- Standards: DIN 3352-1/4, DIN 3840, EN 545, EN 12266
- Coating: Epoxy minimum 250 µm
Colour: Blue, RAL 5017

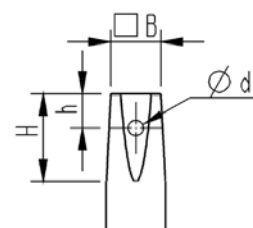

Dimensions stem top:

DN	B	H	h	d
80-150	19,3	28	17	7
200-300	27,3	47	18,5	8

References, dimensions and performances

S-2960:

Dy mm	DN mm	H mm	L mm	L1 mm	Weight kg	Kv m3/h	Z	Esco no.
98	80	330	280	88	15	507	0,2	29600080
118	100	324	300	90	17	792	0,2	29600100
144	125	418	325	90	27	1238	0,2	29600125
170	150	422	350	100	32	2228	0,15	29600150
222	200	535	400	115	55	3960	0,15	29600200

S-2965:

Dy mm	DN mm	H mm	L mm	L1 mm	Weight kg	Kv m3/h	Z	Esco no.
98	80	330	550	210	20	507	0,2	29650080
118	100	324	550	210	22	792	0,2	29650100
144	125	418	550	202	32	1238	0,2	29650125
170	150	422	550	200	38	2228	0,15	29650150
222	200	535	600	190	67	3960	0,15	29650200

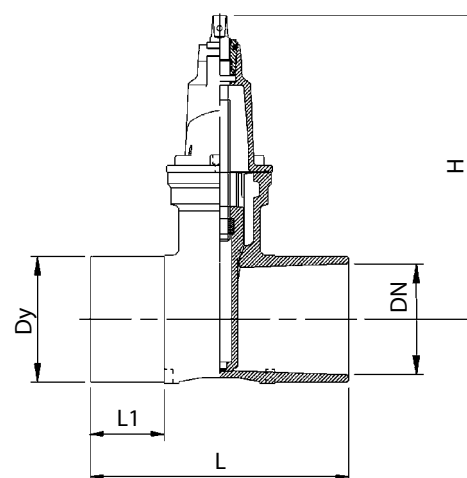

Kongsberg Esco AS can accept no responsibility for possible errors in catalogues, brochures and other printed material. Kongsberg Esco AS reserves the right to alter its products without notice. This also applies to products already on order provided that such alterations can be made without subsequent changes being necessary in specifications already agreed. All trademarks in this material are property of the respective companies. Kongsberg Esco and the Kongsberg Esco logotype are trademarks of Kongsberg Esco AS. All rights reserved.

S-2960/S-2965 Spigot end gate valve DN 80 - 200

F5 lang/ekstra lang byggelengde

03-05/1039002201/06.2009 **3**

Page 2 of 2

Materialspesifikasjon

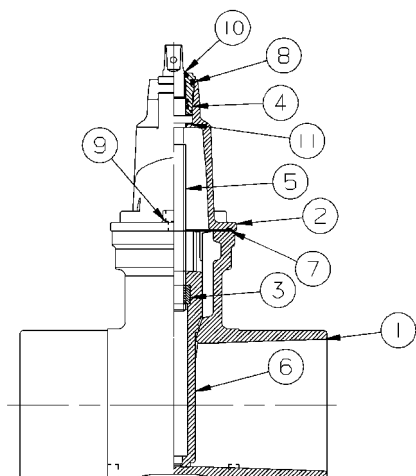

Pos	Detail	Material
1	Body	Ductile iron EN1563 EN-GJS-500-7
2	Bonnet	Ductile iron EN1563 EN-GJS-500-7
3	Stem nut	Dezinkfree brass
4	Stem bushing	Dezinkfree brass
5	Stem	Stainless steel EN10088-3 1.4021
6	Wedge	Ductile iron EN1563 EN-GJS-500-7
7	Gasket	Rubber (NBR)
8	O-rings	Rubber (NBR)
9	Socket head bolt	Steel 8.8
10	Dirt seal	Rubber (NBR)
11	Sleeve bearing	Composite

Installation

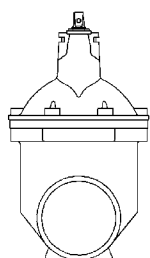

Recommended

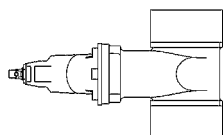

Possible

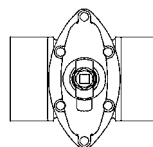

Possible



Not recommended

Accessories and other variants

Accessories:

S-1119 Italian cap
 S-1120/1121 Norwegian cap
 S-1122 Swedish cap
 S-1123 English cap
 S-1124 French cap
 S-1110 Handwheel

S-1880 Spindle extension
 S-1882 Spindle extension with indicator
 S-1830/1835/1840 Operating box

Other variants:

Prepared for actuator
 With electrical actuator
 With pneumatic actuator
 With indicator